

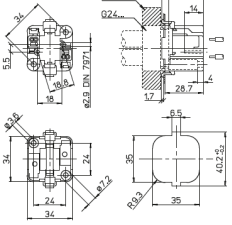





7.2 Pin Compact Fluorescent Lamp Holders

IMAGE	CATALOG NUMBER	LAMP BASE	DIMENSIONS	FIXING METHOD AND LOCATION	TERMINALS	PACK QTY
	PLC401/V	G23		SCREW SIDE OR REAR	PUSHWIRE	50
	PLC402/A INDENT ITEM MOQ 200 PIECES	G23		AUTO TOP CLAMP SCREW REAR	PUSHWIRE	200
	PLC402/L INDENT ITEM MOQ 200 PIECES	G23		AUTO SIDE CLAMP SCREW REAR	PUSHWIRE	200
	PLC404/BU INDENT ITEM MOQ 200 PIECES	G23		SNAP IN FEET	PUSHWIRE	50
	PLC422/AD1-X	G24d-1 GX24d-1 10-13W		AUTO TOP CLAMP SCREW REAR	PUSHWIRE	50
	PLC422/AD2-X	G24d-2 GX24d-2 18W		AUTO TOP CLAMP SCREW REAR	PUSHWIRE	50

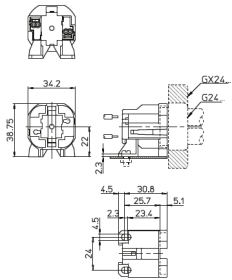
EVE LITECOM - SECTION 7 - LAMP HOLDERS AND CONNECTORS

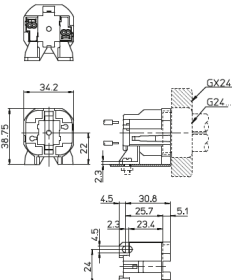
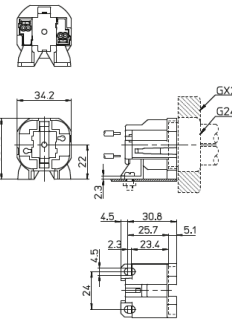
IMAGE	CATALOG NUMBER	LAMP BASE	DIMENSIONS	FIXING METHOD AND LOCATION	TERMINALS	PACK QTY
	PLC422/AD3-X	G24d-3 GX24d-3 26W		AUTO TOP CLAMP SCREW REAR	PUSHWIRE	50
	PLC423/VD1	G24d-1 10-13W		SCREW SIDE	PUSHWIRE	50
	PLC423/VD2	G24d-2 18W		SCREW SIDE	PUSHWIRE	50
	PLC423/VD3	G24d-3 26W		SCREW SIDE	PUSHWIRE	50